

- Cost Effective
- Industry Standard Package
- AC or DC Control
- Panel Mount

Bipolar transistor outputs are available in 3, 5 and 7 amp ratings. Cost-effective relays offer 4000 Volt isolation and come in Crydom's standard panel-mount package.

Manufactured in Crydom's ISO 9001 Certified facility for optimum product performance and reliability.

MODEL NUMBERS	DC CONTROL			AC CONTROL		
	DC60S3	DC60S5	DC60S7	DC60SA3	DC60SA5	DC60SA7
OUTPUT SPECIFICATIONS ①						
Operating Voltage Range [Vdc]	3-60	3-60	3-60	3-60	3-60	3-60
Load Current Range ^② [Adc]	.02-3	.02-5	.02-7	.02-3	.02-5	.02-7
Max. Surge Current, (1 sec) [Adc]	6	10	14	6	10	14
Max. On-State Voltage Drop @ Rated Current [Vdc]	1.3	1.5	1.7	1.3	1.5	1.7
Thermal Resistance Junction to Case (R _{JC}) [°C/W]	2.2	2.2	2.2	2.2	2.2	2.2
Max. Off-State Leakage Current @ Rated Voltage [mA]	0.1	0.1	0.1	0.1	0.1	0.1
Max. Turn-On Time [msec]	0.1	0.1	0.1	10	10	10
Max. Turn-Off Time [msec]	0.3	0.3	0.3	40	40	40

INPUT SPECIFICATIONS ①	DC CONTROL	AC CONTROL
	Control Voltage Range	3.5-32 Vdc
Max. Turn-On Voltage	3.5 Vdc	90 Vrms
Min. Turn-Off Voltage	1.0 Vdc	10 Vrms
Nominal Input Impedence	1500 Ohms	60K Ohms
Typical Input Current	2.2mA @ 5 Vdc	2mA @ 120 Vrms, 4mA @ 240 Vrms

GENERAL NOTES

- ① All parameters at 25°C unless otherwise specified.
 ② Heat sinking required, for derating curves see page 2.

©2003 CRYDOM CORP, Specifications subject to change without notice.



GENERAL SPECIFICATIONS

Dielectric Strength 50/60Hz (input/output/base)	4000 Vrms
Insulation Resistance (Min.) @ 500 Vdc	10 ⁹ Ohm
Max. Capacitance Input/Output	8 pF
Ambient Operating Temperature Range	-30 to 80°C
Ambient Storage Temperature Range	-30 to 125°C

MECHANICAL SPECIFICATIONS

Weight: (typical)	3.0 oz. (86.5g)
Encapsulation:	Thermally Conductive Epoxy
Terminals:	Screws and Saddle Clamps Furnished, Unmounted

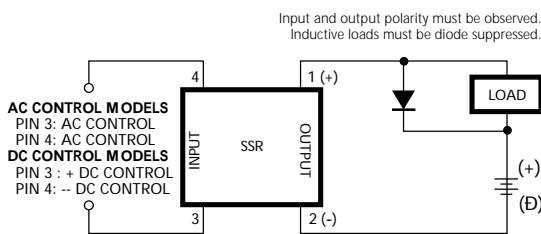

Transient Protection

All loads are inductive, even ones that are not so labeled. An inductive load will produce harmful transient voltages when it is turned off. Diodes should be fast recovery type with PIV rated greater than supply voltage.

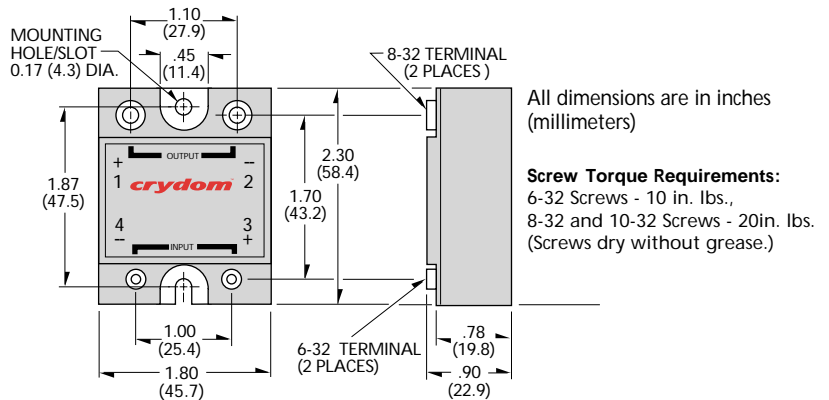

CURRENT DERATING CURVES

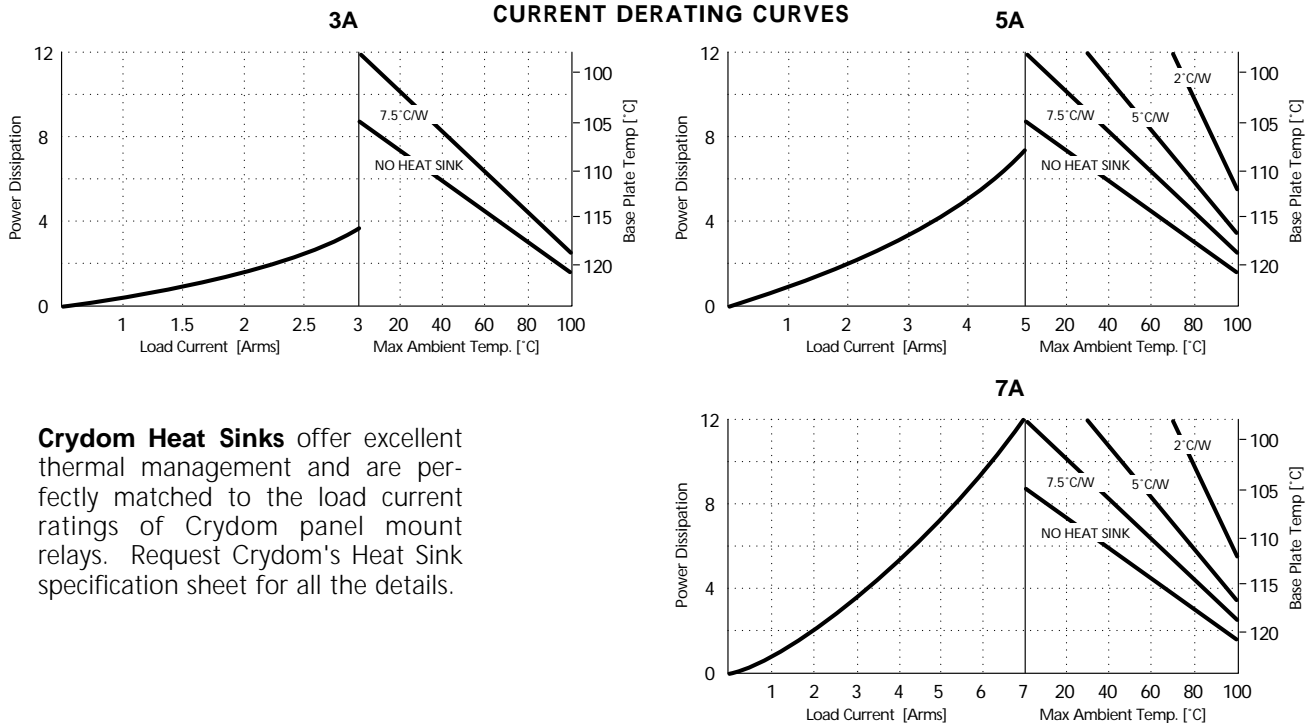

Crydom Heat Sinks offer excellent thermal management and are perfectly matched to the load current ratings of Crydom panel mount relays. Request Crydom's Heat Sink specification sheet for all the details.

©2003 CRYDOM CORP, Specifications subject to change without notice.

